

Agricultural Cylinders

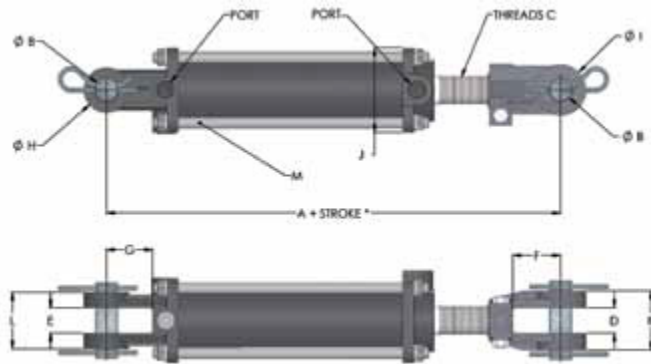

Operating Pressure: 2500 PSI

100% PRESSURE TESTED

AGU Cylinder Dimensions

| | TUBE DIA. | A* | Ø B PIN | C (UNF) | D | E | F | G | H | I | J | K | L | M | PORTS (NPT) |
|-----|-----------|--------|---------|----------|-------|-------|-------|-------|-------|-------|--------|-------|-------|-------|-------------|
| in. | 2.000 | 10.250 | 1.000 | 11/8 -12 | 1.125 | 1.125 | 2.125 | 2.062 | 2.000 | 2.000 | 3.000 | 2.500 | 2.500 | 0.393 | 3/8 |
| mm | 50.80 | 260.35 | 25.40 | | 28.57 | 28.57 | 53.97 | 52.38 | 50.80 | 50.80 | 76.20 | 63.50 | 63.50 | 10.00 | |
| in. | 2.500 | 10.250 | 1.000 | 11/8 -12 | 1.125 | 1.125 | 2.125 | 2.062 | 2.000 | 2.000 | 3.125 | 2.500 | 2.500 | 0.393 | 3/8 |
| mm | 63.50 | 260.35 | 25.40 | | 28.57 | 28.57 | 53.97 | 52.38 | 50.80 | 50.80 | 79.38 | 63.50 | 63.50 | 10.00 | |
| in. | 3.000 | 10.250 | 1.000 | 11/4 -12 | 1.125 | 1.125 | 2.125 | 2.062 | 2.000 | 2.250 | 3.750 | 2.625 | 2.500 | 0.472 | 1/2 |
| mm | 76.20 | 260.35 | 25.40 | | 28.57 | 28.57 | 53.97 | 52.38 | 50.80 | 57.14 | 95.25 | 66.68 | 63.50 | 12.00 | |
| in. | 3.500 | 10.250 | 1.000 | 11/4 -12 | 1.125 | 1.125 | 2.125 | 2.062 | 2.250 | 2.250 | 4.375 | 2.625 | 2.500 | 0.629 | 1/2 |
| mm | 88.90 | 260.35 | 25.40 | | 28.57 | 28.57 | 53.97 | 52.38 | 57.15 | 57.15 | 111.13 | 66.68 | 63.50 | 16.00 | |
| in. | 4.000 | 10.250 | 1.000 | 11/4 -12 | 1.125 | 1.125 | 2.125 | 2.062 | 2.250 | 2.250 | 4.625 | 2.625 | 2.625 | 0.629 | 1/2 |
| mm | 101.60 | 260.35 | 25.40 | | 28.57 | 28.57 | 53.97 | 52.38 | 57.15 | 57.15 | 117.48 | 66.68 | 66.68 | 16.00 | |

| | | A* - STANDARD ASAE CYLINDERS | | | | | | | |
|-----|--|------------------------------|--------------|--------------|--------------|--------------|--------------|--------------|--------------|
| | | 20AGU08-ASAE | 25AGU08-ASAE | 30AGU08-ASAE | 30AGU16-ASAE | 35AGU08-ASAE | 35AGU16-ASAE | 40AGU08-ASAE | 40AGU16-ASAE |
| in. | | 12.250 | 12.250 | 12.250 | 15.500 | 12.250 | 15.500 | 12.250 | 15.500 |
| mm | | 311.15 | 311.15 | 311.15 | 393.70 | 311.15 | 393.70 | 311.15 | 393.70 |

Model Number for AGU

20 AGU XX - (ASAE) - 10

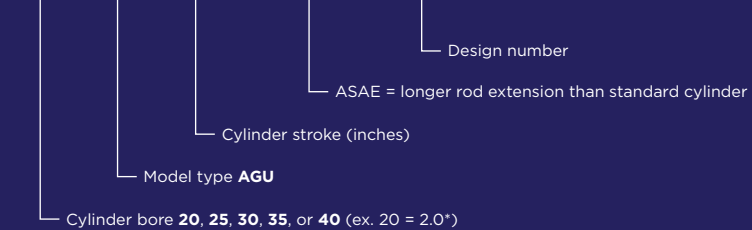

WARNING / ATTENTION

PLEASE NOTE THAT THE MAXIMUM CAPACITY OF CLEVIS PINS ARE:

VEUILLES NOTER QUE LA CAPACITÉ MAXIMUM DES GOUPILLES D'ATTACHEMENT EST DE:

- 1" Ø = 26,000 lbs
- 1-1/2" Ø = 56,000 lbs
- 1-1/4" Ø = 39,000 lbs
- 2" Ø = 96,000 lbs

| MODEL | BORE X STROKE (in.) | ROD DIA. (in.) | CENTER TO CENTER OF PIN (in.) | | PORTS | MAX EXTENSION PRESSURE (PSI) | WEIGHT (lb) | SEAL KIT PART # |
|---------------------|---------------------|----------------|-------------------------------|----------|---------|------------------------------|-------------|-------------------|
| | | | RETRACTED | EXTENDED | | | | |
| MAV 20AGU04-10 | 2 X 4 | 1-1/8 | 14 1/4 | 18 1/4 | 3/8 NPT | 2500 | 16 | MAV AGU 201125-10 |
| MAV 20AGU06-10 | 2 X 6 | | 16 1/4 | 22 1/4 | | | 17 | |
| MAV 20AGU08-10 | 2 X 8 | | 18 1/4 | 26 1/4 | | | 19 | |
| MAV 20AGU08-ASAE-10 | 2 X 8 | | 20 1/4 | 28 1/4 | | | 19 | |
| MAV 20AGU10-10 | 2 X 10 | | 20 1/4 | 30 1/4 | | | 20 | |
| MAV 20AGU12-10 | 2 X 12 | | 22 1/4 | 34 1/4 | | | 22 | |
| MAV 20AGU14-10 | 2 X 14 | | 24 1/4 | 38 1/4 | | | 24 | |
| MAV 20AGU16-10 | 2 X 16 | | 26 1/4 | 42 1/4 | | | 25 | |
| MAV 20AGU18-10 | 2 X 18 | | 28 1/4 | 46 1/4 | | | 27 | |
| MAV 20AGU20-10 | 2 X 20 | | 30 1/4 | 50 1/4 | | | 28 | |
| MAV 20AGU24-10 | 2 X 24 | | 34 1/4 | 58 1/4 | | | 31 | |
| MAV 20AGU30-10 | 2 X 30 | | 40 1/4 | 70 1/4 | | | 36 | |
| MAV 20AGU36-10 | 2 X 36 | | 46 1/4 | 82 1/4 | | 40 | | |
| MAV 25AGU04-10 | 2 1/2 X 4 | | 14 1/4 | 18 1/4 | | 17 | 2500 | MAV AGU 251125-10 |
| MAV 25AGU06-10 | 2 1/2 X 6 | | 16 1/4 | 22 1/4 | | 19 | | |
| MAV 25AGU08-10 | 2 1/2 X 8 | | 18 1/4 | 26 1/4 | | 21 | | |
| MAV 25AGU08-ASAE-10 | 2 1/2 X 8 | | 20 1/4 | 28 1/4 | | 21 | | |
| MAV 25AGU10-10 | 2 1/2 X10 | | 20 1/4 | 30 1/4 | | 23 | | |
| MAV 25AGU12-10 | 2 1/2 X12 | | 22 1/4 | 34 1/4 | | 24 | | |
| MAV 25AGU14-10 | 2 1/2 X14 | | 24 1/4 | 38 1/4 | | 26 | | |
| MAV 25AGU16-10 | 2 1/2 X16 | | 26 1/4 | 42 1/4 | | 28 | | |
| MAV 25AGU18-10 | 2 1/2 X18 | | 28 1/4 | 46 1/4 | | 30 | | |
| MAV 25AGU20-10 | 2 1/2 X20 | | 30 1/4 | 50 1/4 | | 31 | | |
| MAV 25AGU24-10 | 2 1/2 X24 | | 34 1/4 | 58 1/4 | | 35 | | |
| MAV 25AGU30-10 | 2 1/2 X30 | | 40 1/4 | 70 1/4 | | 40 | | |
| MAV 25AGU36-10 | 2 1/2 X36 | | 46 1/4 | 82 1/4 | | 45 | | |
| MAV 30AGU04-10 | 3 X 4 | | 14 1/4 | 18 1/4 | | 22 | 2500 | MAV AGU 301250-10 |
| MAV 30AGU06-10 | 3 X 6 | | 16 1/4 | 22 1/4 | | 24 | | |
| MAV 30AGU08-10 | 3 X 8 | | 18 1/4 | 26 1/4 | | 26 | | |
| MAV 30AGU08-ASAE-10 | 3 X 8 | | 20 1/4 | 28 1/4 | | 27 | | |
| MAV 30AGU10-10 | 3 X 10 | | 20 1/4 | 30 1/4 | | 29 | | |
| MAV 30AGU12-10 | 3 X 12 | | 22 1/4 | 34 1/4 | | 31 | | |
| MAV 30AGU14-10 | 3 X 14 | | 24 1/4 | 38 1/4 | | 33 | | |
| MAV 30AGU16-10 | 3 X 16 | | 26 1/4 | 42 1/4 | | 35 | | |
| MAV 30AGU16-ASAE-10 | 3 X 16 | | 31 1/2 | 47 1/2 | | 36 | | |
| MAV 30AGU18-10 | 3 X 18 | | 28 1/4 | 46 1/4 | | 37 | | |
| MAV 30AGU20-10 | 3 X 20 | 30 1/4 | 50 1/4 | 40 | | | | |
| MAV 30AGU24-10 | 3 X 24 | 34 1/4 | 58 1/4 | 44 | | | | |
| MAV 30AGU30-10 | 3 X 30 | 40 1/4 | 70 1/4 | 50 | | | | |
| MAV 30AGU36-10 | 3 X 36 | 46 1/4 | 82 1/4 | 57 | | | | |
| MAV 35AGU04-10 | 3 1/2 X 4 | 14 1/4 | 18 1/4 | 29 | 2500 | MAV AGU 351250-10 | | |
| MAV 35AGU06-10 | 3 1/2 X 6 | 16 1/4 | 22 1/4 | 31 | | | | |
| MAV 35AGU08-10 | 3 1/2 X 8 | 18 1/4 | 26 1/4 | 34 | | | | |
| MAV 35AGU08-ASAE-10 | 3 1/2 X 8 | 20 1/4 | 28 1/4 | 35 | | | | |
| MAV 35AGU10-10 | 3 1/2 X10 | 20 1/4 | 30 1/4 | 37 | | | | |
| MAV 35AGU12-10 | 3 1/2 X12 | 22 1/4 | 34 1/4 | 39 | | | | |
| MAV 35AGU14-10 | 3 1/2 X14 | 24 1/4 | 38 1/4 | 42 | | | | |
| MAV 35AGU16-10 | 3 1/2 X16 | 26 1/4 | 42 1/4 | 44 | | | | |
| MAV 35AGU16-ASAE-10 | 3 1/2 X16 | 31 1/2 | 47 1/2 | 45 | | | | |
| MAV 35AGU18-10 | 3 1/2 X18 | 28 1/4 | 46 1/4 | 47 | | | | |
| MAV 35AGU20-10 | 3 1/2 X20 | 30 1/4 | 50 1/4 | 50 | | | | |
| MAV 35AGU24-10 | 3 1/2 X24 | 34 1/4 | 58 1/4 | 59 | | | | |
| MAV 35AGU30-10 | 3 1/2 X30 | 40 1/4 | 70 1/4 | 68 | | | | |
| MAV 35AGU36-10 | 3 1/2 X36 | 46 1/4 | 82 1/4 | 76 | | | | |
| MAV 40AGU04-10 | 4 X 4 | 14 1/4 | 18 1/4 | 34 | 2500 | MAV AGU 401250-10 | | |
| MAV 40AGU06-10 | 4 X 6 | 16 1/4 | 22 1/4 | 37 | | | | |
| MAV 40AGU08-10 | 4 X 8 | 18 1/4 | 26 1/4 | 40 | | | | |
| MAV 40AGU08-ASAE-10 | 4 X 8 | 20 1/4 | 28 1/4 | 40 | | | | |
| MAV 40AGU10-10 | 4 X 10 | 20 1/4 | 30 1/4 | 43 | | | | |
| MAV 40AGU12-10 | 4 X 12 | 22 1/4 | 34 1/4 | 45 | | | | |
| MAV 40AGU14-10 | 4 X 14 | 24 1/4 | 38 1/4 | 48 | | | | |
| MAV 40AGU16-10 | 4 X 16 | 26 1/4 | 42 1/4 | 51 | | | | |
| MAV 40AGU16-ASAE-10 | 4 X 16 | 31 1/2 | 47 1/2 | 60 | | | | |
| MAV 40AGU18-10 | 4 X 18 | 28 1/4 | 46 1/4 | 57 | | | | |
| MAV 40AGU20-10 | 4 X 20 | 30 1/4 | 50 1/4 | 60 | | | | |
| MAV 40AGU24-150-10 | 4 X 24 | 34 1/4 | 58 1/4 | 66 | | | | |
| MAV 40AGU24-175-10 | 4 X 24 | 34 1/4 | 58 1/4 | 70 | | | | |
| MAV 40AGU24-200-10 | 4 X 24 | 34 1/4 | 58 1/4 | 75 | | | | |
| MAV 40AGU30-10 | 4 X 30 | 40 1/4 | 70 1/4 | 87 | | | | |
| MAV 40AGU36-10 | 4 X 36 | 46 1/4 | 82 1/4 | 98 | | | | |
| MAV 40AGU36-10 | 4 X 36 | 2 | 31 1/2 | 47 1/2 | 2500 | MAV AGU 402000-10 | | |
| MAV 40AGU18-10 | 4 X 18 | 1-1/2 | 28 1/4 | 46 1/4 | 2300 | MAV AGU 401500-10 | | |
| MAV 40AGU20-10 | 4 X 20 | 1-1/2 | 30 1/4 | 50 1/4 | 1700 | MAV AGU 401750-10 | | |
| MAV 40AGU24-150-10 | 4 X 24 | 1-3/4 | 34 1/4 | 58 1/4 | 2500 | MAV AGU 401750-10 | | |
| MAV 40AGU24-200-10 | 4 X 24 | 1-3/4 | 34 1/4 | 58 1/4 | 2500 | MAV AGU 401750-10 | | |
| MAV 40AGU30-10 | 4 X 30 | 2 | 40 1/4 | 70 1/4 | 2500 | MAV AGU 402000-10 | | |
| MAV 40AGU36-10 | 4 X 36 | 2 | 46 1/4 | 82 1/4 | 2500 | MAV AGU 402000-10 | | |

*Stocked in limited quantity.